

G. E. MILLER.
RECESSING TOOL FOR LATHES.

No. 605,184.

Patented June 7, 1898.

Fig. 1.

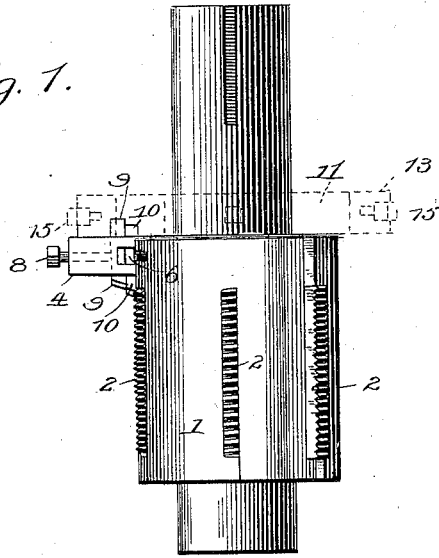
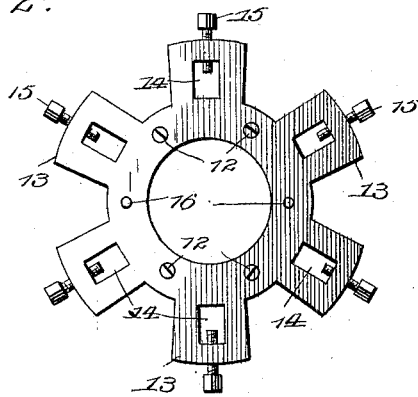

Fig. 2.



WITNESSES:

Harry S. Rohrer,
Marcus L. Byng.

INVENTOR

George E. Miller.

BY *John Weddaburn*

ATTORNEY.

(No Model.)

2 Sheets—Sheet 2.

G. E. MILLER.
RECESSING TOOL FOR LATHES.

No. 605,184.

Patented June 7, 1898.

Fig. 3.

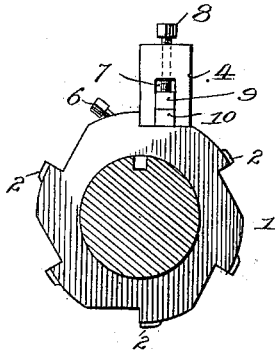

Fig. 4.

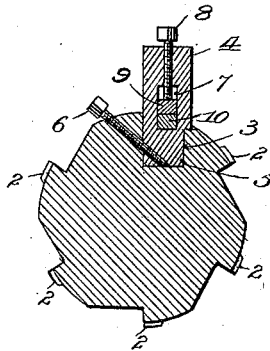
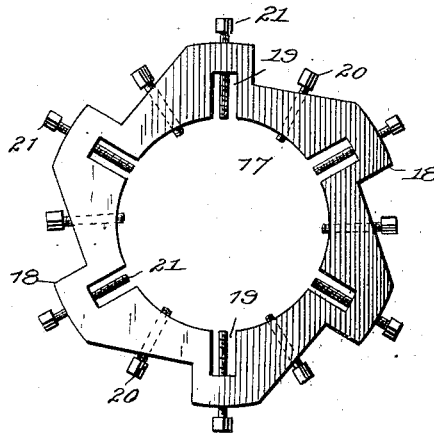

Fig. 5.



WITNESSES:

Harry S. Robins.
Marcus L. Byng.

INVENTOR

George E. Miller
BY *John Weddubum.*
ATTORNEY.

UNITED STATES PATENT OFFICE.

GEORGE E. MILLER, OF MIDDLETOWN, PENNSYLVANIA, ASSIGNOR OF ONE-HALF TO JOHN W. ALBRIGHT, OF SAME PLACE.

RECESSING-TOOL FOR LATHES.

SPECIFICATION forming part of Letters Patent No. 605,184, dated June 7, 1898.

Application filed December 18, 1896. Serial No. 616,180. (No model.)

To all whom it may concern:

Be it known that I, GEORGE E. MILLER, a citizen of the United States, residing at Middletown, in the county of Dauphin and State of Pennsylvania, have invented certain new and useful Improvements in Recessing-Tools for Lathes; and I do hereby declare the following to be a full, clear, and exact description of the invention, such as will enable others skilled in the art to which it appertains to make and use the same.

My invention relates to recessing-tools for lathes.

My object is to provide a novel form of recessing device adapted to be carried by a tap of the expanding type, so that in tapping and recessing couplings or similar pieces of work the two operations of tapping or threading and recessing may be carried on simultaneously, thereby saving much time and labor. Ordinarily the tapping or threading of the coupling is first accomplished, and then the recessing and facing are done with a separate device fed up by hand. My improved device, described hereinafter, does away with the necessity of two operations.

Having this and other minor objects in view, the invention consists of certain improved features and novel combinations of parts appearing more fully hereinafter.

In the accompanying drawings, Figure 1 is a side elevation showing the tap and tool-holder; Fig. 2, a detail plan view of said tool-holder; Fig. 3, a rear view of the tap, disclosing the tool-post; Fig. 4, a cross-section of the same, and Fig. 5 a detail plan view of a tool-holding cutter.

Referring now to the devices disclosed in Figs. 1 and 2, the numeral 1 designates an expanding-tap of ordinary construction, which has the movable threaded cutter-bars 2. Reference being had to Figs. 3 and 4, it will be seen that the tap is provided with a pocket 3 of rectangular shape.

The numeral 4 designates a tool-post, having a tenon 5 adapted to snugly fit within the pocket.

The numeral 6 represents a diagonally-disposed screw which secures the tenon in the pocket. This tool-post has a slot 7, 8 representing a clamping-screw which passes down

through the tool-post into the slot. The tool-post can be made to hold one or more tools, and in the present instance two are shown, they being designated by the numerals 9 and 10. The tool 10 serves as a recessing-tool and projects toward the free end of the tap farther than the tool 9, which acts as a facing-tool for the coupling or other piece being acted on.

In Figs. 1 and 2 I have shown a tool-holder adapted to contain a number of tools. This is designated by the numeral 11, and it is secured by screws 12 to the rear end of the tap and the arbor of the latter. Said tool-holder has a number of posts 13, each having a slot 14.

The numerals 15 designate clamping-screws provided for each post, and it will be seen that a number of tools can be used. If desirable, additional pins 16 could be employed to secure the holder in position.

My improved cutter is shown in detail in Fig. 5. This cutter is slipped over the tap, and it is designated by the numeral 17, the cutting-teeth thereof being shown at 18. There are a series of radial slots 19, leading from the inner edge of the cutter outward in line with the highest points of the teeth. Clamping-screws 20, passing through the inclined faces of the teeth, serve to hold the cutter on the tap, while additional clamping-screws 21 pass through the teeth and project into the slots, being adapted to secure the recessing-tools in said slots and against the face of the tap. It is obvious that it is necessary to remove the tool-post 4 before the cutter can be slipped on the tap. As many of the tools can be placed in the openings 19 of the cutter as desirable. The cutter can then be used as a facing-tool. Of course the clamping-screws 21 cannot be used when the cutter itself is employed to recess, although they remain in position when the cutter is only used for facing. The coupling to be threaded and recessed is gripped in the carriage, (which, being swiveled, is adapted to turn horizontally in a complete circle,) and the tap is held in a chuck or wedged in the spindle of the lathe head-stock. The carriage is fed up to the tap and the feed put on, so that the carriage will advance by itself. The tap en-

ters in the coupling and threads the same. The recessing-tool next comes up and recesses the coupling, and the facing-tool finally faces off the outer end of the coupling, these operations being carried on at the same time. 5
Of course it is necessary to separate the recessing and facing tools the distance that it is desired to recess the coupling. After these operations have been completed, the coupling 10 being threaded from one end to its center, the tap is contracted, so that the thread-cutter bars are withdrawn from the threads made in the coupling and the carriage is moved back. The swivel portion of the carriage 15 is then turned so as to present the other end of the coupling, and the operation before described may then be repeated.

It will be seen that much time and labor are saved in using my improved devices, as the 20 operations are carried on simultaneously.

Inasmuch as the depth between the recessing and facing tools and the distance between the point of the thread-cutting bars and said tools remain constant after the device has 25 been adjusted all the couplings will be turned out similar. If it is desired to make a longer coupling, the tools can be adjusted backward, and if a smaller coupling is wanted they can be adjusted forward.

30 Having thus described my invention, what I claim as new, and desire to secure by Letters Patent, is—

1. In a recessing-tool, the combination with

a tap having a recess or pocket, of a tool-holder carried thereby provided with a tenon 35 engaging said recess or pocket and with a tool slot or opening, independently-adjustable recessing and facing tools superposed one in relation to the other and in diametrical relation to the tap in said opening, and a 40 clamping-screw passing through the tool-holder and binding on said tools.

2. In a recessing-tool, the combination with a tap, of a tool holder or post having a portion received in said tap, a screw whose 45 shank passes through the tap and into the post and is adapted for holding the latter in position, and a tool secured in said tool-holder.

3. In a recessing-tool, the combination with a tap provided with a recess, of a tool holder 50 or post having a reduced portion which fits in said recess and said post extending diametrically in relation to the tap and provided with an opening, an inclined screw whose shank passes through the tap and into the 55 reduced portion of the post, independent recessing and facing tools located in the holder, and a clamping-screw threaded into the said post or holder and binding on the tools.

In testimony whereof I have signed this 60 specification in the presence of two subscribing witnesses.

GEORGE E. MILLER.

Witnesses:

JOHN W. ALBRIGHT,
SAMUEL MILLER.